



# Energy, Economic and Environmental analysis of Methyl Acetate Process

Nagamalleswara Rao. K

Department of Chemical Engineering, School of Civil and Chemical Engineering,  
VIT University, Vellore, Tamil Nadu, India

**Abstract:**In this work, energy-economic and pollution analysis studies were conducted for methyl acetate production process. Methyl acetate production process was designed using ASPEN PLUS V8.8 simulating tool. Energy analysis using ASPEN ENERGY ANALYZER suggested 33.5 % of energy saving potential of the designed process. Retrofit studies for the base case HEN (Heat Exchanger Network) saved 16.9% of the total energy for the addition of one new heat exchanger. Payback period reported as 0.8515 years. Economic analysis using ASPEN ECONOMIC ANALYZER suggested that there is a possibility of reducing 38% of utility cost. Environmental analysis using WAR (Waste Reduction Algorithm) reported decrease in pollution levels by modifying the existing process.

**Key words:** ASPEN PLUS V8.8, Economic Analysis, Energy Analysis, HEN.

## 1. Introduction

Industrial effluents represents a significant environmental and economic problem<sup>1</sup>. Pollution is the result of unconverted raw materials, untreated wastes<sup>2,3</sup> and industrial accidents<sup>4</sup>. Various pollution control measures are suggested for controlling industrial pollutants in open literature<sup>5,6-11, 50, 51</sup>. Various examples for controlling pollution reported in literature are: pharmaceutical industries uses reverse distributors for the collection of unwanted pharmaceuticals from Pharmacies and Health Care Centers<sup>12,13</sup>, Conversion of waste to reusable products<sup>14</sup>, treating industrial waste water by Coagulation-Flocculation Treatment methods<sup>15</sup>, Electro-chemical oxidation in rotating cathodes in electro-chemical reactors<sup>16</sup>, toxic chemicals removal by adsorption techniques<sup>17,18,19</sup>, by using selective membranes<sup>20</sup>, Phytoremediation in controlling the pollution of soil, water, or air<sup>21</sup>, Defluoridation techniques for fluorine removal<sup>22</sup> represents some of the pollution treatment techniques. Now a days Green chemistry is the one of the chemical synthesis technique in minimizing pollution<sup>23</sup>. Pollution can be minimized by following correct process design techniques<sup>24,25,26</sup>, and by providing plant wide control studies<sup>27-30,31</sup>.

Environmental impacts can be reduced by designing sustainable processes<sup>32,33,27</sup>. Sustainability can be defined as meeting the needs of this generation without compromising the needs of future generations<sup>34</sup>. Source reduction, recycle and reuse are the waste minimization techniques generally using in the process industries. Source reduction deals with the reduction of waste at the source itself, rather than the "end of the pipe" treatment<sup>35</sup>. Source reduction measures can include, process modifications<sup>36</sup>, process integration<sup>37,52</sup>.

Designing energy efficient systems by pinch technology is one of the process integration technique<sup>38,39,40,41</sup>. Optimization of production processes using process simulators like ASPEN PLUS and MATLAB is one of the techniques used to minimize energy losses<sup>42</sup>. Several metrics or indicators are used to measure the process sustainability. Metrics or Indicators have been used as quantitative measures of sustainability issues such as resource usage, profit and environmental impact. Several metrics and or indicators have been proposed by the American Institute of Chemical Engineers<sup>43</sup>, Institution of Chemical Engineers (IChemE) and the Environmental Protection Agency (EPA)<sup>44,45</sup> implemented an indicator based analysis using material and

energy balances. The developed indicator is able to identify design targets through a sensitivity analysis procedure<sup>46</sup>. Several automated tools such as the SUSTAINABILITY EVALUATOR<sup>47</sup>, Gensym<sup>48</sup>, Sustain-Pro<sup>46</sup> and the Waste Reduction Algorithm (WAR)<sup>45</sup> have been developed to identify and evaluate sustainability concerns in chemical process design. These tools save time in accessing the sustainability concerns of a process since these metrics have been incorporated into computer based platforms.

In this work, ASPEN PLUS V8.8 chemical process simulating tool is used to design methyl-acetate production process and its environmental impacts were assessed with WAR algorithm. The WAR uses an index based system to characterize potential pollution reductions for a chemical process using report files from a process simulator such as ASPEN PLUS or CHEMCAD<sup>49</sup>. In this paper process modifications suggested for minimum wastes and maximum profit. The procedure employed in this research includes designing and process simulation using ASPEN PLUS V8.8 chemical process simulating tool and potential environmental impacts were calculated using WAR algorithm and process modifications were suggested to minimize the pollution or by reducing the waste.

## 2. Methodology

Process was designed for the production of Methylacetate and it was shown in figure 1. Energy and economic analysis were conducted using ASPEN ENERGY ANALYZER and ASPEN ECONOMIC ANALYZER. Environmental impacts of pollutants were assessed using WAR algorithm. After that recycle stream was inserted to the base case process and the modified process is shown in figure 2. Again economic, energy and environmental assessments conducted for the modified process. Environmental impact assessment is carried out by WAR algorithm. The WAR algorithm evaluates processes in terms of potential environmental impacts. The Potential Environmental Impact or PEI of a chemical is defined as the effect that a chemical would have on the environment if it were simply emitted into the environment. WAR algorithm assesses the environmental friendliness of the manufacturing portion of the product life cycle. WAR characterizes the PEI of the streams entering and leaving the process boundaries. WAR includes PEI from eight categories. They are: Human Toxicity Potential by Ingestion (HTPI), Human Toxicity Potential by Exposure (HTPE), Aquatic Toxicity Potential (ATP), Terrestrial Toxicity Potential (TTP), Global Warming Potential (GWP), Ozone Depletion Potential (ODP), Smog Formation Potential (PCOP), Acidification Potential (AP). To facilitate the use of the WAR algorithm, EPA scientists developed WAR GUI, the Waste Reduction Algorithm Graphical User Interface. WAR GUI is a freely available program that allows users to enter the necessary data for the WAR algorithm: The flow rate and composition of each stream entering and leaving the chemical process.

### 2.1 Base case Process

The proposed design for the production of methyl acetate consists of heat exchangers, compressors, plug flow reactor, flash column and distillation columns.

#### Reaction kinetics:

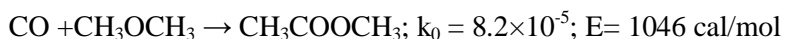

Feed to vaporizer (B1) is at 273K, 32 atm with a flow rate of 250 kmol/hr. Feed composition is 0.999 mole fraction of dimethyl ether and 0.001 mole fraction of methyl alcohol. Feed is heated to 372 K. Feed to the compressor (B2) contains 262 kmol/hr carbon monoxide and 5.24 kmol/hr hydrogen. Feed conditions are 273K and 5 atm. This feed is compressed to 32 atm. Compressor type is isentropic. Feed from the compressor and the vaporizers are mixed and sent to the plug flow reactor (B4) for the reaction.

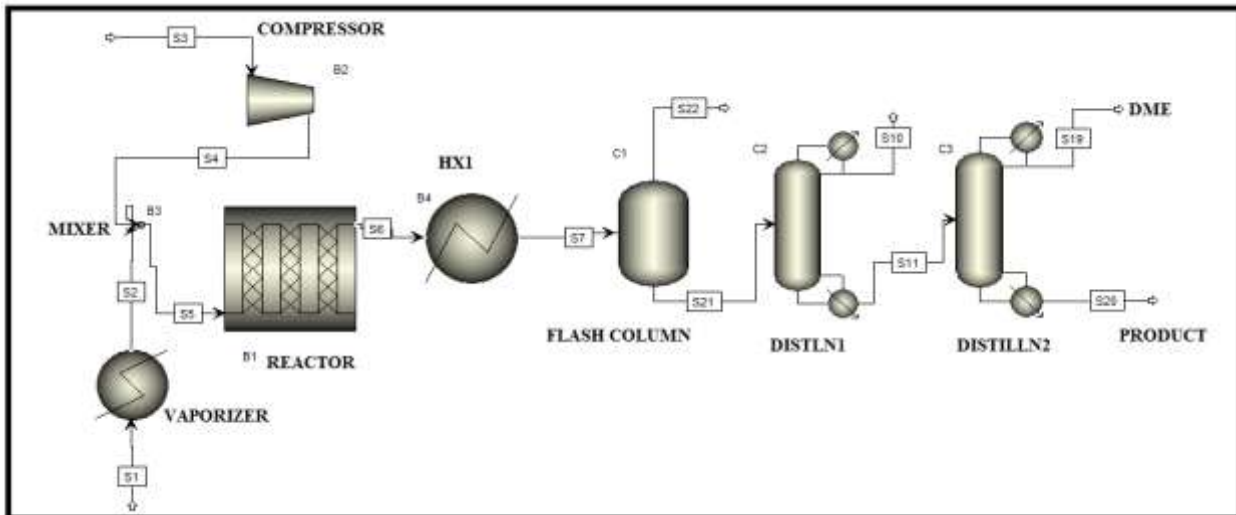

Figure 1. Base case process flow sheet for case one

Reactor type is adiabatic and the configuration of the reactor is length 10m, diameter 0.5 m and number of tubes are 1000. Catalyst loading is 48800 kg, Bed voidage 0.4. Reactor outlet stream is send to Heater (B5). Heater is used to increase the temperature of the reactor effluent to 580K. Heated reactor outlet is passed to the Flash column (C1). Column conditions are Temperature 320K and pressure 30 atm. Here unreacted reactants are separated. Bottoms of the flash column are send to the Distillation column (C2). Column C2 is Distil, column configurations are condenser is partial, number stages are 17, feed stage location is 2, distillate to feed mole ratio 0.8, reflux ratio 1.32, condenser pressure 5 atm and reboiler pressure 5.16 atm. Here DME and Methyl acetate are separated. Bottoms from the column C2 rich of Methyl acetate is send to the Distillation column (C3). Column C3 type is Distil, column configurations are condenser is total, number stages are 17, feed stage location is 5, distillate to feed mole ratio 0.6, reflux ratio 1.32, condenser pressure 5 atm and reboiler pressure 5.16 atm. Here DME and Methyl acetate are separated.

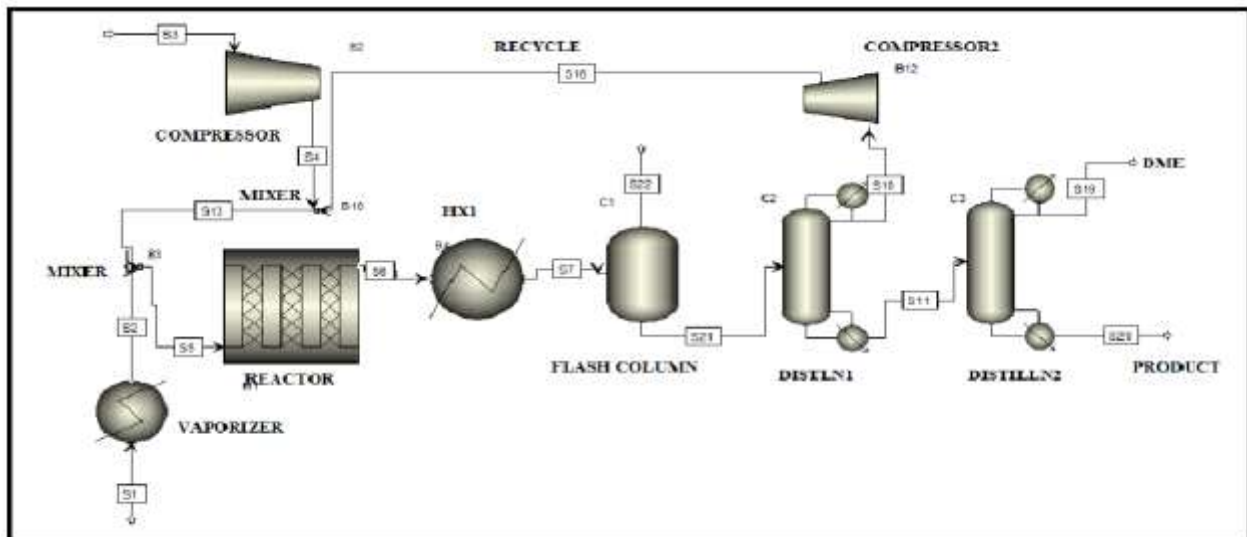

Figure 2. Process flow diagram for case 2 with recycle loop

## 2.2 Modified Process

Unreacted reactants from the distillation column 1 tops are recycled back as feed to the reactor. One more compressor (B12) is used to regain the reactor pressure and a mixer is used (B10) to link the reactant feed from compressor one (B2), feed from the vaporizer and the recycle stream (S16).

### 3. Results and Discussion

#### 3.1 ASPEN PLUS Simulation Results

The simulation results for the two processes are shown in table 1 and in table2 respectively. By comparing the two, in the base case process the waste steam S10 contains large amounts of unreacted dimethyl ether and small amounts of carbon monoxide. It is logical to recover the Dimethyl ether and carbon monoxide as the waste reduction strategy. So the process flow diagram was modified by inserting the recycle stream from stream S10 to the feed stream S5. By doing this step 50% of the dimethyl ether is recovered. From the simulating results it was identified that the recycle increased the amount of product by 299% while simultaneously reducing the amount of waste dimethyl ether.

**Table 1. Flow summary (kmol/hr) Input and Output for Base case process**

Stream Name	S1	S3	S10	S19	S20	S22
Carbon Monoxide (CO)	0	262	4.049	0	0	190.3
Dimethyl Ether (DME)	249.75	0	125.0	8.24E-13	0	57.13
Methyl Acetate (MEACH)	0	0	26.62	23.3	15.5	1.974
Hydrogen (H <sub>2</sub> )	0	5.24	0.008	0	0	5.231
Methanol (MEOH)	0.25	0	0.236	9.02E-07	3.2E-11	0.013
Total Flow kmol/hr	250	267.24	155.9	23.3	15.5	254.7

**Table 2. Flow summary (kmol/hr) Input and Output for Modified process**

Stream Name	S1	S3	S19	S20	S22
Carbon Monoxide (CO)	0	262	0	0	198.1248
Dimethyl Ether (DME)	249.75	0	92.24416	1.27422E-08	93.64169
Methyl Acetate (MEACH)	0	0	1.000191	62.3182	0.5573657
Hydrogen (H <sub>2</sub> )	0	5.24	0	0	5.239992
Methanol (MEOH)	0.25	0	0.240661	0.00515248	0.0041866
Total Flow kmol/hr	250	267.24	93.48501	62.32334	297.568

By the examination of table 1 and table 2, it will indicate that waste was generally reduced at the same time environmental impact was probably also reduced. But the above information considered is not sufficient to allow a quantitative comparison of the overall waste and environmental impact reduction associated with each of these two cases. For this comparison impact indexes are to be calculated.

#### 3.2 Energy and economic Analysis

Energy analysis was performed for the base process using ASPEN ENERGY ANALYZER. From energy analysis there is a provision for saving 32.96% of the actual energy was identified. As a part of that first the process was modified by inserting a recycle stream and is shown in figure 2. By inserting recycle stream 16% of the energy get saved. To check the further energy savings Heat Exchanger Network for the modified process was designed and it is shown in figure 3. Designed HEN is subjected to retrofit studies. In retrofit studies one new heat exchanger is added to the existing HEN. Heat exchanger is added between condenser @B14 to stream S19. The retrofit HEN diagram is shown in figure 4.

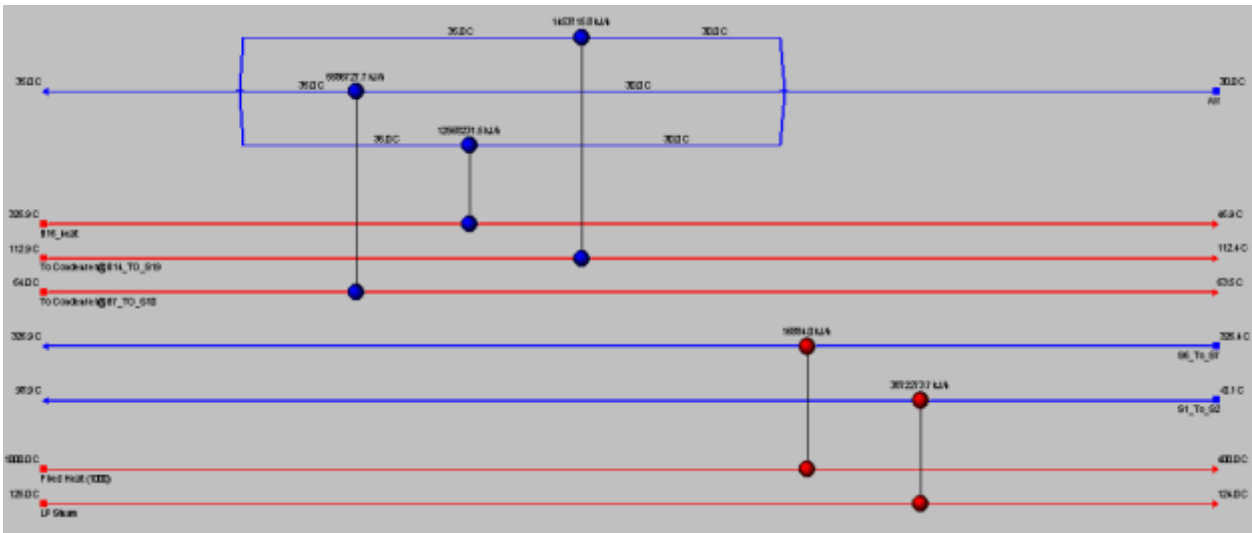

Figure.3 Base Case HEN

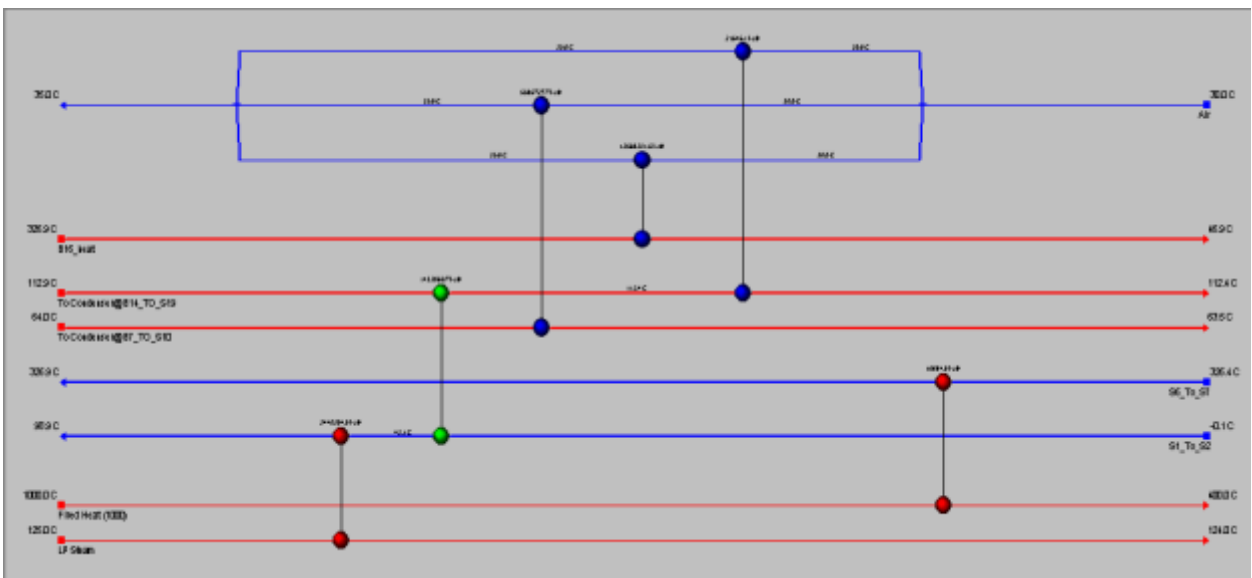

Figure 4. Retrofit HEN

Table 3. Economic Comparisons

Cost	Base Case Process	Modified Process
Total Capital Cost [USD]	8672520	8493650
Total Operating Cost [USD/Year]	3439130	2815810
Total Utilities Cost [USD/Year]	1567110	1015110
Equipment Cost [USD]	2514800	2245400
Total Installed Cost [USD]	3336500	3110800

From table 3 it is evident that the modified process operating cost and utility costs are low.

### 3.3 Potential environmental Impact index (PEI) calculations

Potential environmental indexes (PEI) are calculated using WAR algorithm. PEIs are shown in figure 5 for the base case process and for the modified process. Table 4 gives the individual PEI values of each category of impacts.

**Table 4. Total output rate of PEI (PEI/hr)**

Case	HTPI	HTPE	TTP	ATP	GWP	ODP	PCOP	AP	TOTAL
Case One	7.16E+02	2.54E+01	7.16E+02	5.6	2.04	3.08E-9	2.27E+03	9.06E-3	3.73E+03
Case Two	6.85E+02	2.58E+01	6.85E+02	5.39	2.15	6.52E-7	2.31E+03	1.92	3.71E+03

**Figure 5. Impact index graphs for two cases**

Figure 5 shows the impact generation index for the two design cases. It is evident that impact indexes for case one are more compared to case two. This indicates that the decrease of these indexes reflects the increase in the productivity of the plant, i.e. increase in product flow rate. These decreases in the indexes are sufficiently large that they represent very significant reductions in pollution.

#### 4. Conclusions

Energy, economic and environmental impact assessment for Methyl acetate production process, using ASPEN PLUS family tools and WAR algorithm was developed. The methodology used for the production of methyl acetate process can be used for any other production process. The process plants designed using these methodologies are economically feasible and environmentally friendly. Results from the WAR algorithm showed that modified process is more ecofriendly to the atmosphere by reducing the cost and pollution.

#### 5. Acknowledgment

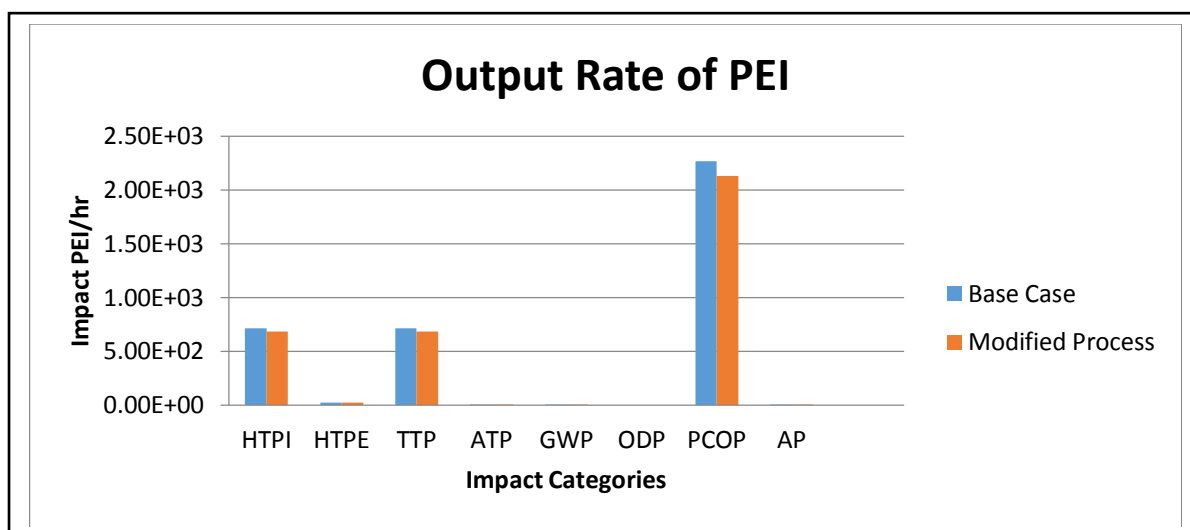
Author is thankful to VIT University for providing ASPEN PLUS software to successfully complete this research work.

#### References

1. E. J. Saravana Sundaram, R. Elayaperuma, M. Kiruthika, V. Ramya and P. Dharmalingam., Effluents of Paper Mill: Physico-Chemical Properties of Water, International Journal of ChemTech Research, Vol.6, No.7, pp 3541-3545, Sept-Oct 2014.
2. Sushma and Jitender Pal., Performance Of UASB Reactor At Different Flow Rate Treating Sewage Wastewater, International Journal of ChemTech Research, Vol.5, No.2, pp 676-681, April-June 2013

3. M. Suneetha, B. Syama Sundar and K. Ravindhranath., Studies on Defluoridation Techniques: A Critical Review, *International Journal of ChemTech Research*, Vol.8, No.8, pp 295-309, 2015.
4. Koteswara Reddy G, Kiran Yarrakula., Analysis of Accidents in Chemical Process Industries in the period 1998-2015, *International Journal of ChemTech Research.*, Vol.9, No.04 pp177-191, 2016.
5. Marimuthu K.N, Ruby Thomas, B. Yamini, S. Bharathi and K. Murugavel., Water pollution due to dyeing effluents in Noyyal river, Tirupur-A case study, *International Journal of ChemTech Research*, Vol.7, No.7, pp 3075-3080, 2015.
6. Shu H., Two-phase production of cyclohexene and Cyclooctene oxides in water as approach topollution prevention, *Journal of Chemical Technology and Biotechnology*, 2005, 80, 273-280.
7. Ulrich G, Vasudevan P., Predesign for pollution prevention and control, *ChemicalEngineering Progress.*, 2007, 103:6, 53-59.
8. El-Halwagi M, Stephanopoulos G, Pistikopoulos E., *Process integration*, Process Systems Engineering. Academic Press, San Diego, CA, USA. 2006, ISBN:10:0123705320.
9. Genaidy A, Sequeira R, Tolaymat T, Kohler J, Rinder M., Evidence-based integrated environmental solutions for Secondary lead Smelters: pollution prevention and wasteminimization technologies and practices. *Science of the Total Environment.*, 2009, 407:10, 3239-3268.
10. Cortes M, Salgado Y, Suarez E., Mass integration for pollution prevention, *Afinidad.*, 2010, 67:547, 193-197.
11. Tock L, Gassner M, Maréchal F., Thermochemical production of liquid fuels from biomass: thermo-economic modeling, process design and process integration analysis. *Biomass and Bioenergy.*, 2010, 34:12, 1838-1854.
12. Kumari Shalini, Zaihra Anwer, Pramod Kumar Sharma, Vipin Kumar Garg, Nitin Kumar., A Review on Pharma Pollution, *International Journal of PharmTech Research.*, Vol.2, No.4, pp 2265-2270.
13. Muthumani S and Anbuselvi S., Waste Management and Environment Protection – A Study with Isolation and Characterisation of Low Density Polyethylene Degradating Microbes, *International Journal of ChemTech Research*, Vol.7, No.6, pp 2841-2845, 2014-2015.
14. B. Bharathiraja, D. Yogendran, R. Ranjith Kumar, M. Chakravarthy, S. Palani., Biofuels from sewage sludge- A review, *International Journal of ChemTech Research.*, Vol.6, No.9, pp 4417-4427, September 2014.
15. Ronke Ruth Ayangunna, Saidat Olanipekun Giwa, Abdulwahab Giwa., Coagulation-Flocculation Treatment of Industrial Wastewater Using Tamarind Seed Powder, *International Journal of ChemTech Research.*, Vol.9, No.05 pp 771-780, 2016.
16. Rathinakumaran.K and Meyyappan.Rm., Electro-chemical oxidation of Acid Blue 9 using DSA anode and rotating cathode in electro-chemical reactor., *International Journal of ChemTech Research*, Vol.8, No.3, pp 1203-1211, 2015.
17. X.Michael Nirmal and T.Ragupathi., Experimental Study on Reduction of Chromium Content from Industrial Effluent using Banana Peel, *International Journal of ChemTech Research*, Vol.8, No.6, pp 725-731, 2015.
18. K. Ravindhranath and B. Sreenivasa Reddy., Leaves and Barks of Some Plants as Bio-Adsorbents in the Control of Methylene Blue Dye from Waste Waters, *International Journal of ChemTech Research.*, Vol.6, No.14, pp 5612-5624, Nov-Dec 2014.
19. J.S. Sudarsan, K.Prasanna, G.Baskar, Radhika Babu George., Role of Titanium Oxide Nanoparticle on Heavy Metal Reduction in Electroplating Waste Water Treatment, *International Journal of ChemTech Research*, Vol.7, No.2, pp 547-553, 2014-2015.
20. A.Brinda Lakshmi, S.Sindhu, S.Venkatesan., Performance Of Ionic Liquid As Bulk Liquid Membrane For Chlorophenol Removal, *International Journal of ChemTech Research*, Vol.5, No.3, pp 1129-1137, April-June 2013.
21. P. Mullai, M. K. Yogeswari, K. Saravanakumar, K. Kathiresan., Phytoremediation of heavy metals using *Avicennia marina* and *Rhizophora mucronata* in the Uppanar River, *International Journal of ChemTech Research*, Vol.6, No.12, pp 4984-4990, October 2014.
22. Vivek Prakash Pankaj., Sustainable model of Plastic waste management, *International Journal of ChemTech Research*, Vol.7, No.01, pp 440-458 2014-2015.
23. S. Ravichandran., Green Chemistry - A Potential tool for Chemical Synthesis, *International Journal of ChemTech Research.*, Vol.2, No.4, pp 2188-2191, Oct-Dec 2010.
24. Koteswara Reddy G, Kiran Yarrakula., Identification of Research Trends in Chemical Process Design: A Review, *International Journal of ChemTech Research*, Vol.9, No.05 pp 585-595, 2016.

25. Nagamalleswara Rao K., Chemical Engineering Projects Case Studies Using ASPEN PLUS, ASPEN DYNAMICS and ASPEN ENERGY ANALYZER
26. Nagamalleswara Rao K., HYSYS and ASPEN PLUS in Process Design A Practical Approach,
27. Nagamalleswara Rao K., Design and control of Acrolein production process, Emerging Trends in chemical engineering.,2014, 1:2,27-34.
28. Nagamalleswara Rao K., Design and control of Acetaldehyde production process, Emerging Trends in Chemical Engineering., 2014, 1:1, 11-21.
29. Nagamalleswara Rao K., Design and Control of Ethyl Acetate Production Process, Emerging Trends in Chemical Engineering., 2015, 2:1,9-20.
30. Nagamalleswara Rao K., Design and control of Acrylic acid production process, Emerging Trends in Chemical Engineering., 2014, 1:1, 1-10.
31. Nagamalleswara Rao K., Design and Energy Analysis of Butyl Acetate Plant using Aspen HYSYS and Aspen Energy Analyzer, Emerging Trends in Chemical Engineering., 2014, 1:2, 15-26.
32. Sikdar S., Sustainability and recycle-reuse in process systems, Clean Technologies and Environmental Policy., 2007, 9:3, 167-174.
33. Bhaskar Mazumder, Sanjib Bhattacharya and Abhishek Yadav., Total Quality Management in Pharmaceuticals: A Review, International Journal of PharmTech Research, Vol.3, No.1, pp 365-375, Jan-Mar 2011.
34. Brundtland G., Our Common Future: The World Commission on Environment and Development. Oxford University Press, Oxford, 1987, United Kingdom.
35. Bandyopadhyay S., Source composite curve for waste reduction, Chemical Engineering Journal., 2006, 125, 99-110.
36. Halim I, Srinivasan R., Systematic waste minimization in chemical processes. 3. Batch operations, Industrial Engineering Chemistry., 2006, 45:13, 4693-4705.
37. Tock L, Gassner M, Maréchal F., Thermochemical production of liquid fuels from biomass: thermo-economic modeling, process design and process integration analysis. Biomass and Bioenergy., 2010, 34:12, 1838-1854.
38. K. Nagamalleswara Rao., Pinch analysis of Acrylic Acid Process Plant, International Journal of ChemTech Research, Vol.9, No.06 pp 432-439, 2016.
39. G.Himabindu., Process Integration Route For Water Conservation In Industrial Plants, International Journal of ChemTech Research, Vol.5, No.3, pp 1124-1128, April-June 2013.
40. Nagamalleswara Rao K, Pinch Analysis of Cumene Process Using Aspen Energy Analyzer, International Journal of Chemical Engineering and Processing., 2015, 1:1, 21-30.
41. Nagamalleswara Rao K, Pinch analysis of Acetone production process using Aspen Energy Analyzer, Emerging Trends in Chemical Engineering., 2014, 1:3, 25-33.
42. E. Ardeshiri-Gilani, A.M.Astaraki., Production and purification of hydrogen in Catalytic Micro reactor with Aspen plus software and optimization of reactor temperature with genetic algorithms in Matlab software, International Journal of ChemTech Research, Vol.9, No.08 pp 495-504, 2016.
43. Cobb C, Schuster D, Beloff B, Tanzil D., The AIChE sustainability index: the factors in detail, Chemical Engineering Progress., 2009, 105:1, 60-63.
44. Young D, Scharp R, Cabezas H., The waste reduction (WAR) algorithm: environmental impacts, energy consumption, and engineering economics, Waste Management., 2000, 20 :8, 605-615.
45. Young D.M, Cabezas H., Designing sustainable processes with simulation: the waste reduction (WAR) algorithm, Computers & Chemical Engineering., 1999, 23:10, 1477-1491.
46. Carvalho A, Gani R, Matos H., Design of sustainable chemical processes: systematic retrofit analysis generation and evaluation of alternatives, Process Safety and Environmental Protection., 2008, 86:5, 328-346.
47. Shadiya O., Social Economic and Environmental Metrics for the Sustainable Optimization of Chemical and Petroleum Processes [Dissertation]. Stillwater: Oklahoma State University., 2010.
48. Halim I, Srinivasan R., A knowledge-based simulation-optimization framework and system for sustainable process operations, Computers & Chemical Engineering., 2011, 35 :1, 92-105.
49. Seay J, Eden M., Incorporating environmental impact assessment into conceptual process design: a case study example, Environmental Progress & Sustainable Energy., 2008, 28:1,30-37.
50. Mohammad Razif, Soemarno, Bagyo Yanuwidi, Arief Rachmansyah., Effects of Wastewater Quality and Quantity Fluctuations in Selecting the Wastewater Treatment Plant: a Case Study of Surabaya's Mall, International Journal of ChemTech Research, Vol.8, No.2, pp 534-540, 2015.



51. Hemant W. Khandare., Scenario of Nitrate contamination in Groundwater: Its causes and Prevention, International Journal of ChemTech Research, Vol.5, No.4, pp 1921-1926, April-June 2013.
52. Nagamalleswara Rao K., Design and Pinch Analysis of Mono-Isopropyl Amine Production process Using Aspen plus and Aspen Energy Analyzer, Emerging Trends in Chemical Engineering., 2014, 1:3,15-24.

\*\*\*\*\*